

PCB Layout (Pattern side)

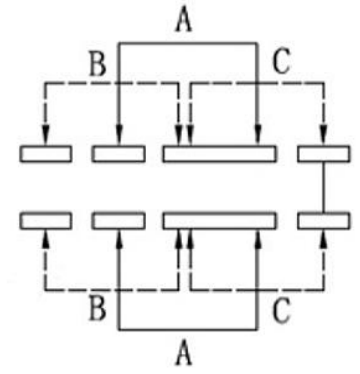
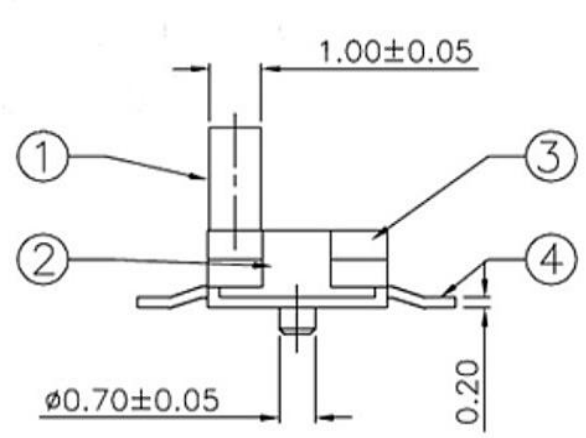
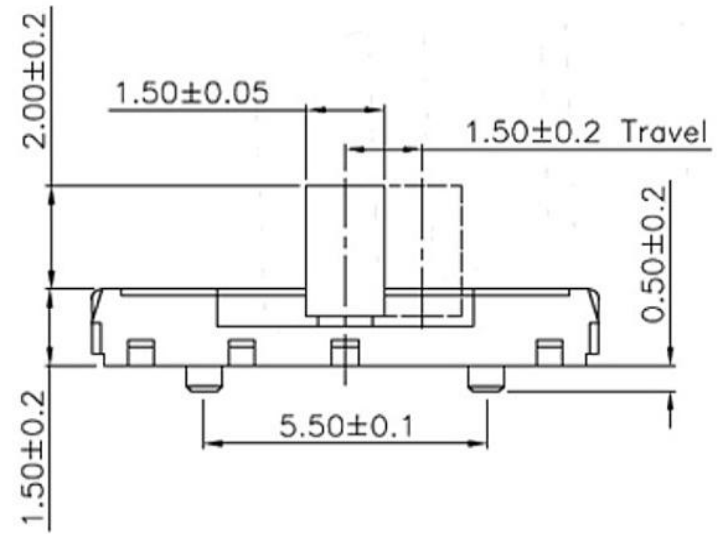

Circuit Diagram

注: "*"表示关键尺寸(6个)

8					TOLERANCE					
7	STEEL BALL	STEEL	1	NATURAL	UNLESS SPECIFIED					
6	SPRING	STEEL WIRE	1	NATURAL	WITHIN		A	2012-10-26	初版	
5	CONTACT CLIP	PBS STRIP	2	Ag PLATED	OVER		ISSUE	DATE	DESCRIPTIONS OF REVISION	
4	TERMINAL	BRASS STRIP	8	Ag PLATED	TITLE : SLIDE SWITCH			UNIT : mm	DRWG NO.:	
3	BASE	PHENOLIC RESIN	1	NATURAL	MODEL:			SCALE: 3:1	DWN.	2012-10-26
2	FRAME	STEEL STRIP	1	Ni PLATED	东莞市高迪电子有限公司 DONGGUAN GAODI ELECTRONICS CO., LTD.			APPD.		2012-10-26
1	KNOB	POM	1	BLACK				APPD.		
NO.	PARTS	MATERIALS	Q'TY	FINISH						